

SUNTECH®



# *Trust YOURSELF Trust Your Decision*

*Your trusted metal fabricator in Asia  
Our Commitment to Best Performance for a Sustainable Future*

# with **GLOCAL** MIND



## Index

SHOKUNIN ————— P.2

LEARNING CENTER ————— P.4

    Concept ————— P.4

    Factory Building ————— P.5

    Office Building ————— P.6

Nakama ————— P.10

WORKS ————— P.12

SDGs ————— P.14

COMPANY ————— P.16

## About Us

Manufacturing team from Japan with a glocal mindset

Since its establishment in 1977, Suntech Co., Ltd. has been engaged in the design and manufacturing of stainless steel tanks, heat exchangers, vacuum dryers, pressure vessels, and other factory machinery. In addition to plant manufacturers from around the world, our customers come from a diverse range of industries including water supply, sewage, chemical, food, pharmaceutical, paper, steel, and semiconductors. Not only do we manufacture excellent products, but as a leading manufacturing company, we also want to share our technology and mindset with the world to enrich the international community.

# SHOKUNIN



There is a traditional Chinese idiom that says, “drink water, think source.” In other words, when we drink water, we should think about the people who drew the water or dug the well. It means that we are always indebted to others, and that we should not forget that. This phrase is the foundation of all of Suntech’s corporate activities. We do not merely live, but are kept alive by others; and with this idea in mind, we hope to contribute not only to Japan, but also to the world and the people living in it. This is the reason for our existence as a company – our purpose. To this end, we commit ourselves to the world, while retaining a glocal mindset from the small town of Ayagawa in Kagawa, Japan.

Building products builds character;  
building character builds the planet

President and CEO *Hiromi Aoki*

## Corporate Mission

Contributing to the actualization  
of a Sustainable Global Society through  
the craftsmanship of JAPAN

Being a shokunin (craftsperson) is not a job, but a mindset and a sense of professionalism. A shokunin is a person who never compromises and continually hones their skills with pride. We are proud to be professionals that lead Japan in the design and manufacturing of plant equipment. Using the solid technological capabilities we have cultivated over many years, we have manufactured products that have a high level of complexity, such as heat exchangers that can withstand temperatures of more than 1,000°C, ultra-high vacuum tanks and pressure vessels. Suntech’s top-level shokunin, who are masters of their trade, are the reason why Suntech is able to achieve a level of precision down to the millimeter, even on massive products more than ten meters long.

# SUNTECH Learning Center

People work to live, and through work they learn and grow. Many people from all over the world come to Kagawa, Japan, where Suntech is located, to learn the skills and spirit of manufacturing. We have already welcomed people from more than 30 countries, including Mauritania, Guinea, Chad, Cote d'Ivoire, Ghana, Senegal, Cambodia, South Africa, as well as South Sudan, where political unrest and the humanitarian crisis continues, and Syria, from where refugees have fled persistent civil conflict.

We have named our new building the Suntech Learning Center, to make it a place of learning for everyone, and together with Suntech China and Mooz & Company Myanmar and Suntech Patana, we will continue to create useful products for the world with a glocal mindset. From the world to Japan, from Japan to the world. With a pledge for world peace and gratitude in our hearts for those who "dug the well."



Entrance hall with a feeling of spaciousness



Open kitchen serving delicious meals



Artificial turf for children and adults to relax in the "living room"



Increased security using facial recognition



Crane embossed with the "Family is First" slogan in the factory building

# Factory Introduction

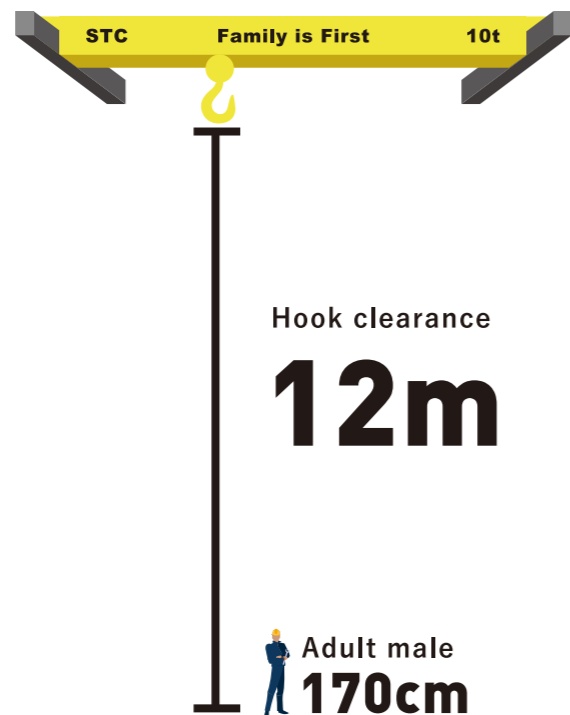
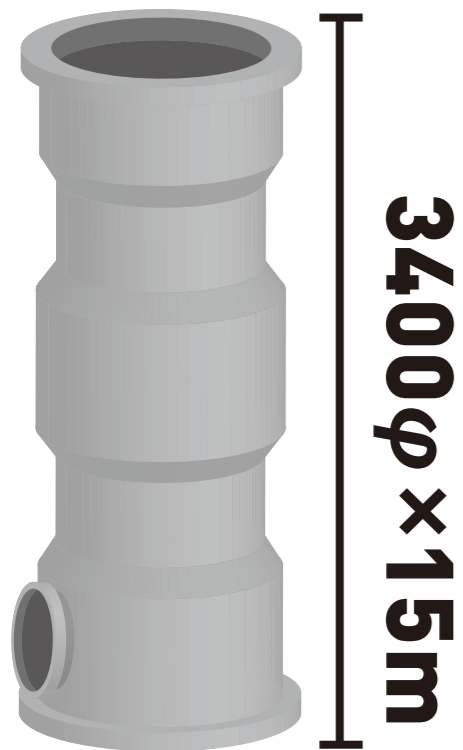
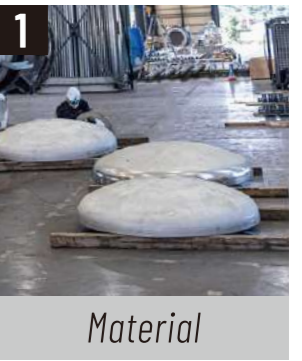
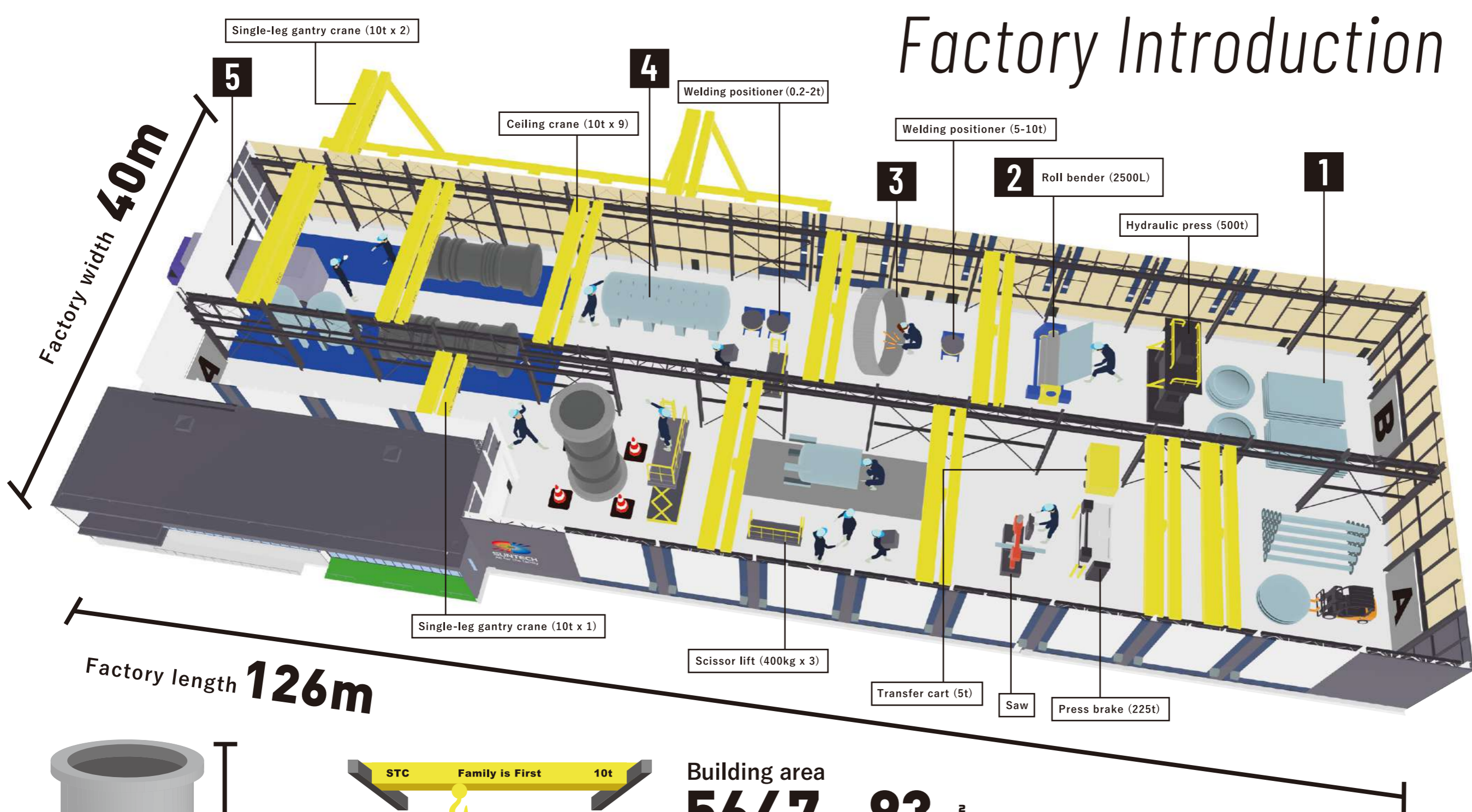

Building area **5647.93m<sup>2</sup>**

Site area **16750.43m<sup>2</sup>**

**93m<sup>2</sup>**

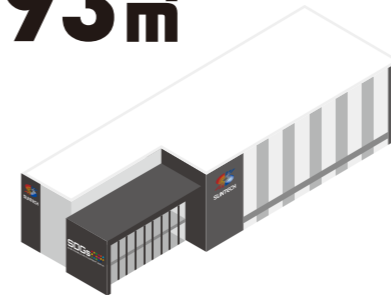

**SUNTECH :**

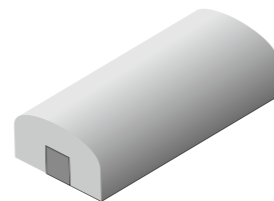

**LAB**

Until the time of shipping the products that were manufactured in our factory, we in Suntech preserve these products in our specified warehouse, a place where we can also experiment new businesses.

Building area **2,002.62 m<sup>2</sup>**

Completion **March 2021**

Construction Daiwa House Industry Co., Ltd.

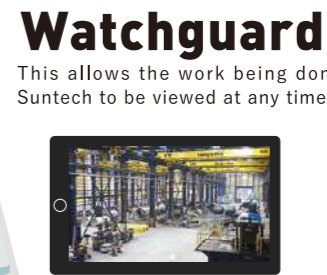

**Watchguard**

This allows the work being done in Suntech to be viewed at any time.



# 1st floor

## A “living room” for comfortable downtime

This floor has a reception area, where we have staff are on hand to welcome guests. The entire floor has been named the “living room,” in the hope that it will be a place where the Suntech family can feel at home. It can be used by anyone who visits our company. In addition to table seating and sofa seating, there is also a section covered with artificial grass where people can relax. We aim to be a healthy company by providing well-balanced meals prepared by our registered nutritionists and chefs.

# 2nd floor

## Diverse workstyles



The second floor includes meeting spaces, a café counter, and desk space. Employees can choose their own workspace depending on the task, without being limited to their own desk. They may choose to use the sofas or counters, working alone or in a group – a variety of possible workstyles. There is also space that can be used as a prayer or mindfulness room, a unique part of Suntech, where people from various countries and regions work together.



# Family Garden

Our building is surrounded by grassy areas, with cherry blossom trees planted in one corner. We created the Family Garden for the entire Suntech family to enjoy, including activities such as cherry blossom viewing parties right on company grounds. We hope it will become a space where many people can relax.





# Nakama



## Aiming to be a world-class welding instructor

Joined Suntech after obtaining certification as an International Welding Engineer. He continues to study every day with the goal of becoming an instructor who can train world-class welders.

QUALITY MANAGEMENT DEPARTMENT DIRECTOR Masahide Ogawa



## A bridge between Suntech and China

Introduced to Suntech through a company information session for foreign exchange students. Using his high-level language skills, he works as the contact point between Suntech and Suntech China.

GLOBAL PROCUREMENT DIVISION CHIEF Meng Zibo



## From Japan to the World - Building the Foundations of Tomorrow's Society, Together

Joined Suntech after discovering the company through a job-hunting website for international students, while studying in Japan as a student from Thailand. Now, she serves as a bridge between Suntech and Suntech Patana, striving to expand awareness of Japanese manufacturing in Thailand.

SALES & MARKETING DEPARTMENT Poonyaporn Suthamporn

## Coordinating communications with high-level language skills

Obtaining N1 certification, the highest level of the Japanese Language Proficiency Test, she joined Suntech as a full-time employee from her native Myanmar. She uses her language skills to interpret for technical interns and take calls from overseas.



INTERNATIONAL AFFAIRS DEPARTMENT Kyi Kyi Thein

## Studied sign language to communicate welding techniques to deaf people

Specialist who has obtained certification as a special-class boiler welder. After observing manufacturing overseas, he realized that craftsmanship has no borders, and is currently studying sign language to convey welding techniques to deaf workers.



ADVISOR Keizo Bessho

## A craftsperson in the kitchen, supporting the Suntech crew with food

A cook who shares Suntech's commitment to "the spirit of craftsmanship" and supports staff with food. Taking the tastes and beliefs of international students into consideration, she creates dishes suited for each individual. Using her wide range of knowledge and skills in her cooking, she is a true shokunin.



REGISTERED NUTRITIONIST Shiho Yanagise



Heat Exchanger

Industry: Water and sewage



First Pressure Vessel

Class-1 Pressure vessel  
Industry: Food



Utility Can

Utility can for sugar refinery  
Industry: Food



Column Unit

Industry: Pharmaceutical



Palpa Tank

Palpa tank for  
National Printing Bureau  
Industry: Paper manufacturing



Flue Compensator

Industry: Water and sewage



[suntech.link/works/](https://suntech.link/works/)

# Works

With our proven experience and skills, we have built a strong track record in Japan, a country known for advanced technology. We are proud to say that no other company can manufacture plant equipment at this level of complexity. For this manufacturing, our integrated in-house production system ensures high quality and flexible delivery. We are able to meet the diverse needs of our customers because we have the technology to support their technology.

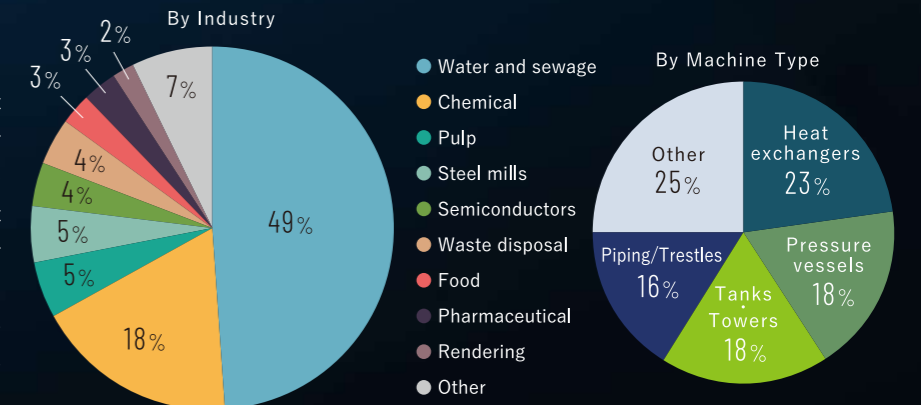



## Suntech's commitment to the SDGs

Our corporate philosophy is to enrich the international community through Japanese manufacturing, and we support the Sustainable Development Goals (SDGs) to contribute to and support the realization of a better international society.



# SUSTAINABLE DEVELOPMENT GOALS

As the successors of the Millennium Development Goals (MDGs) established in 2001, the Sustainable Development Goals (SDGs) are listed in the 2030 Agenda for Sustainable Development, which was adopted unanimously by member states at the UN Summit in September 2015. The SDGs are a set of global goals for achieving a better and more sustainable world by the year 2030. Consisting of 17 goals and 169 targets, they pledge to "leave no one behind." The SDGs are universal, applicable not only to developing countries, but also to developed countries themselves, and Suntech is actively involved in their implementation.

## Tackling environmental issues with Suntech technology



### Safeguarding Everyday Life from Air Pollution

Suntech's heat exchangers help recycle waste heat generated during factory exhaust gas treatment.



### Initiatives to Address the Growing Issue of Water Pollution

Japan's water treatment technologies are renowned worldwide. At Suntech, we support this process by manufacturing large-scale pipes and essential equipment—contributing to solving global water challenges.



## Studying technology to promote economic growth in various countries



Moоз & Company Myanmar, located in the Thilawa Special Economic Zone A (SEZ) of Yangon, the largest city in Myanmar, is a new company created through a joint investment by Suntech and Xen Group. This opening of the factory was a major dream of the two owners, with the start of this grand project dating back to 2015.

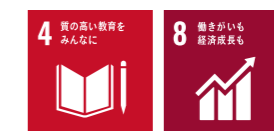

GRAND OPENING CEREMONY



We also accept interns internationally, with people from all across the globe coming to Suntech to learn about our technology and approach.



▲Visitors are welcomed by the flags of the countries of people working at Suntech



▲Two interns who studied in Japan are now working back in Myanmar.



▲This photo was featured at the Tokyo International Conference on African Development (TICAD 8).



## Quality Policy

We will conduct our business in the safest and best environment for our families.

We will carry out our business activities with honesty and security for our communities.

We will provide the best quality of goods and services for our customers.

We will follow our quality policy with passion, compassion, intelligence, and will continue to improve.

## Company

Company name	Suntech Co., Ltd.	Members of the Board	President & CEO Hiromi Aoki Senior Managing Director Ozora Aoki Executive Managing Director Ayumi Iwasaki Director Minoru Takagi
Headquarters	2137-1 Hayukashimo, Ayagawa-cho, Ayauta-gun, Kagawa Prefecture, 761-2308, Japan	International standard	ISO9001:2015
Founded	August 2, 1977	Construction permit number	Kagawa Prefectural Governor Permission (General-7), No. 5615 Pipe construction, steel construction, machinery and equipment installation
Established	June 18, 1991	Factory certification	Japan Water Works Association Inspection Certified Plant for Class 1/Class 2 pressure vessels
Capital	25 million yen		

### SUNTECH Learning Center Access Map

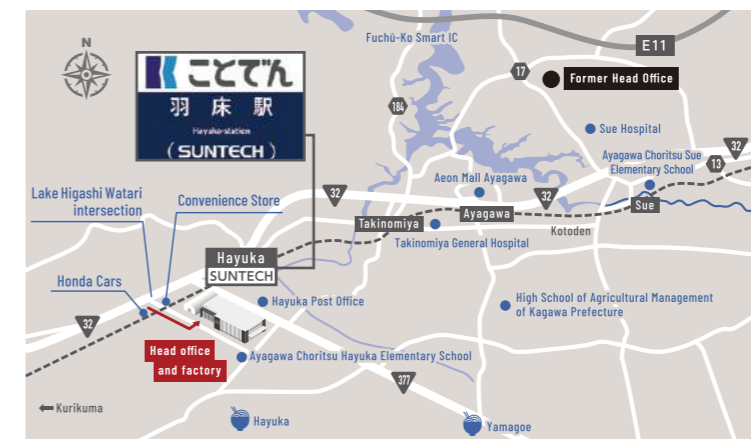

2137-1 Hayukashimo, Ayagawa-cho, Ayauta-gun, Kagawa, 761-2308 Japan  
TEL : 087-876-1600  
FAX : 087-876-0300



Scan here for updates from Suntech.

[suntech.link/news/](https://suntech.link/news/)

## OFFICE LIST

### TOKYO OFFICE

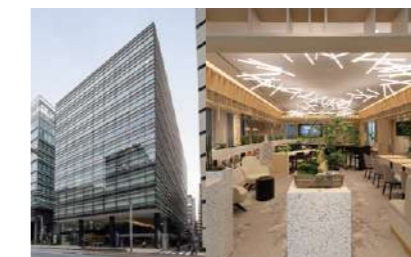

1F Nihonbashi Front, 3-6-2 Nihonbashi, Chuo-ku, Tokyo, Japan 103-0027

### OSAKA OFFICE



2F Breeze Tower, 2-4-9 Umeda, Kita-ku, Osaka-shi, Osaka, Japan 530-0001



### SUNTECH CHINA



Office address: Rm 602, Bldg 42, No. 1000 Jinhai Rd, Pudong, Shanghai, P.R.China 201206  
Factory address: No.26 Haiyan Road, Hi-Tech Industry Development Zone, Qidong, Jiangsu Province, P.R.China 226200



### MOOZ & COMPANY MYANMAR



Lot No.D3, Thilawa SEZ Zone A, Thanlyin Township, Yangon, Myanmar.11291



### SUNTECH PATANA



31/3 Radniyom Road, Tambol Nernpra Muang Rayong Thailand 21150

Manufacturing group from *Japan* with a glocal mindset

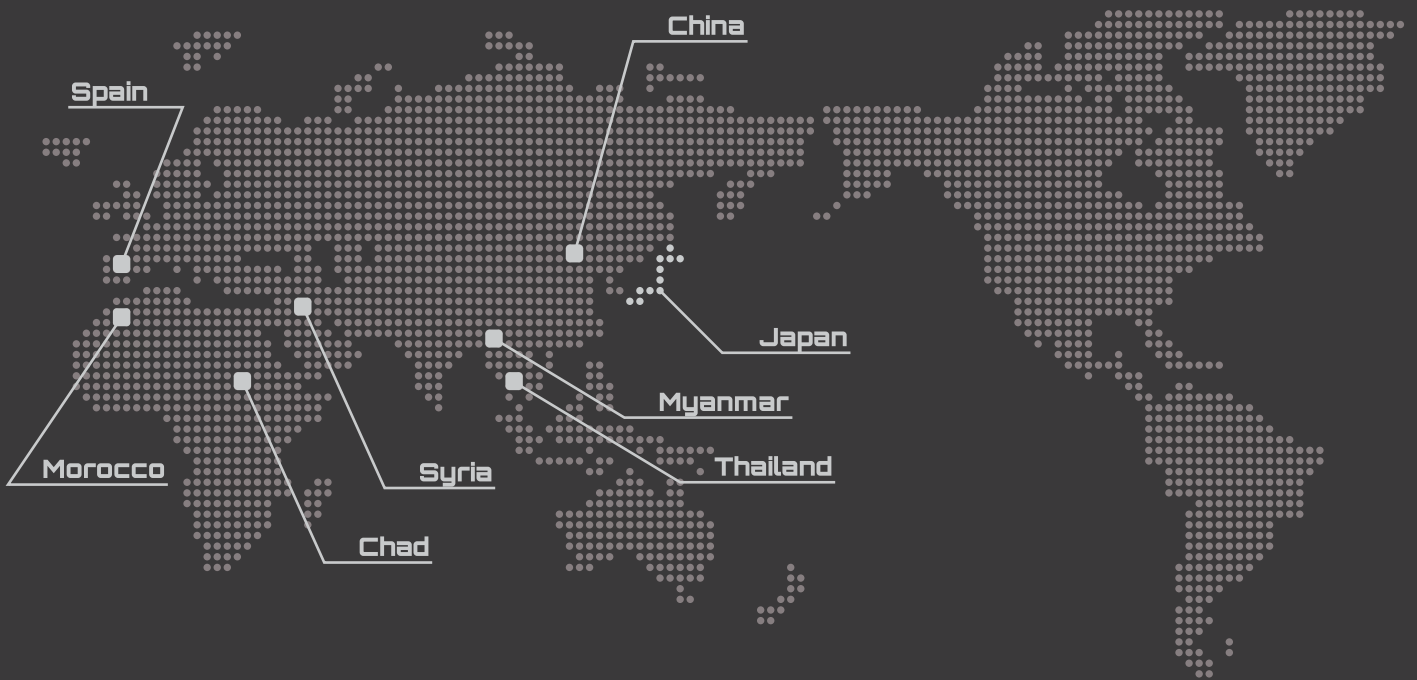

[suntech.link](https://suntech.link)